

Directory

- 一、Product Overview
- 二、The circuit interface
- 三、The main performance
- 四、The module of basic instructions (voltage, protocol, size, baud rate, etc. description)
- 五、The state description (such as matching state and how to abandon the memory address of re-paired memory, etc.)
- 六、AT command set (the user can modify the baud rate, user name, etc.)

一、Product Overview

HC-04 Bluetooth Serial core modules: This design uses CSR's Bluetooth chips, V2.0 protocol standards, industry-standard: 28mm x 15 mm x 2.35mm, the volume size of a compact self-efficient on-board antenna, transparent serial port with a variety of Bluetooth adapter, paired Bluetooth mobile phone use, but also the use of a pair of master and slave.

HC-04-D Bluetooth serial module with a backplane,: This design is a HC-04 module, coupled with external circuit based on the floor, the working voltage is from 3.3V to 5V, leads to TTL, and 232, matching the success of the signal LED pin, the host module also leads to re-search for new slaves pin (default master and slave memory matching addresses will be down, if the next time there are multiple simultaneous Bluetooth, the host will automatically find previously paired off from the machine, if the high electrical pulse to this pin is to give up memory).

The software contains the factory default AT command set, as detailed in point 6 of the instructions.



HC-04

HC-04-D

-04-D 套件

二、the circuit interface:

RS232 serial port (TTL level), (also equipped with a floor-level serial port 232), matching the success of the signal I (pair of

flashing), the host module containing the words "give up the original memory module address from the machine and re-search Module "signal pins.

三、 The main properties:

Band: 2.40GHz—2.48GHz , ISM Band

Bluetooth protocol: BlueTooth V2.0 protocol standard

Power Level: Class2 (+6dBm)

Receiver sensitivity: -85dBm

Operating Voltage: 3.3V (Threshold voltage: 3.0V~4.2V) With a floor voltage is: 3.3V~5V;

Temperature: -40°C ~+105°C

Reference energy: Waiting for a search is 35 mA

Connect on-line is about 8 mA

四、 THE Module of basic instructions:

1. Use of CSR as a mainstream Bluetooth chip , Protocol standard is Bluetooth V2.0
2. The Bluetooth serial port core modules is HC-04; working voltage is: 2.7-3 .3 V.
3. Serial port module backplane HC-04-D with an RS232 interface and TTL interfaces, optional use of an interface, use 3.3 to 5V power supply. Serial port is transparent to the users.
4. Bluetooth chip is forward error-correcting codes, communication more efficient, automatic frequency-hopping anti-jamming ability.
5. Baud rate is
1200, 2400, 4800, 9600, 19200, 38400, 57600, 115200, 230400, 460800, 921600, 1382400 Users can set it.
6. Size of the core module: 28mm x 15 mm x 2.35mm, Power Supply is 3.3V.
7. Size of bottom: 27mm * 47mm (10 of the above can be customized size).
8. Reference Current: 35mA/8mA
9. Reference Sleep Current: <1mA.
10. For the GPS navigation system, utility meter reading systems, industrial control systems on-site mining, Bluetooth printer, Bluetooth mobile phones and other wireless modules medical monitoring applications.
11. With Bluetooth laptop computer to a Bluetooth adapter , PDA and other devices to connect seamlessly.

五、 THE Status Description:

1. The module is to use points in two ways:
 - In pairs, a master-slave, respectively, then serial port (when shipped with a good right, power to individual modules, Flash slowly for the host, the slave flash for faster). Master and slave does not require drivers when used in pairs, two modules

will be able to transmit power.

- The slave plane be used with the Bluetooth adapter, Bluetooth adapter need driver. This module can be used with notebook, PDA, Bluetooth mobile phones and other equipment directly, matching the password is "1234."

2. Module of the LED lights flicker state means that are paired
3. Module on the bright LED lights that match long-finished, this time serial feature has already started.
4. A master-slave pairs normal use LED lights will not die out. If the master and slave can not connect caused by far away, then the master and slave flash the lamps have been; when the master and slave near again to the appropriate location, it will return to normal function, this time, the host will automatically and the original from the machine matched pair. If you need to re-pair from the plane, it would take to host module backplane 1,2 feet short circuit a few seconds (or in between the legs plus keys), this time the host would be to abandon the original allocation from the machine, re-search of new slave .

Note: This description is mainly directed against the Bluetooth serial port module with a backplane, if it is the core module, the LED lights on the module PIO3 the corresponding pin.

Interface Drawings: (8 PIN interface, from the bottom floor of view, square pad for the first leg)

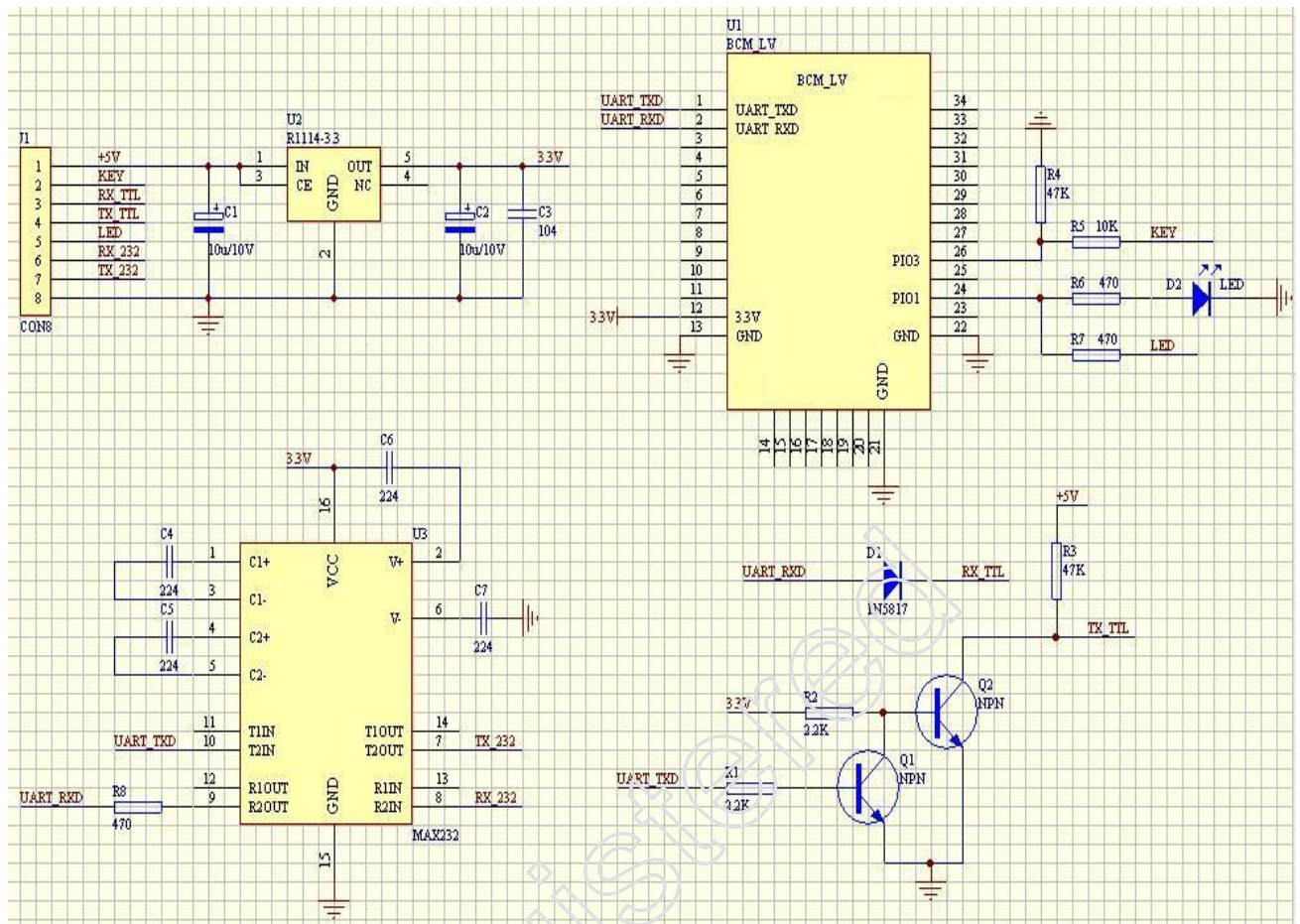

六、AT Command Set:

1. Tips:

If you press the factory default baud rate to use, do not want to modify the baud rate of the content can be without regard to the following:

The AT command is used to master and slave.

Paired use, the master and slave can be different baud rate can also pass each other data, but the host and the device connected with the host baud rate to be the same,

From the machine and with the slave devices connected to the same baud rate also.

2. Set up your hardware connections:

Before sending AT commands to ensure that the hardware connections are as follows:

The PIN with an eight-floor interface, the first leg then external power supply (3.3 to 5V), the sixth foot then the computer COM1 (DB9 male) population of the third foot, seventh-pin COM1 port then the computer second legs, 8th Then the computer COM1 port of the Fifth foot pin.

3. Setting method:

The initial communication parameters are 9600, N, 8,1, before the

matching (ie matching flashing light flashing or when PIO3 time) to send commands modify the baud rate, using HyperTerminal or the assistant to open the computer COM1 serial debug port, enter the Text "AT" to send manually.

A、 Test communications

Send: AT (back OK, about once a second)

Returns: OK

B、 Bluetooth Serial communication baud rate change:

Send: AT + BAUD1

Returns: OK1200

Send: AT + BAUD2

Returns: OK2400

1-----1200
2-----2400
3-----4800
4-----9600
5-----19200
6-----38400
7-----57600

8-----115200
9-----230400
A-----460800
B-----921600
C-----1382400

Not recommended for use in more than 115.2 thousand baud rate, because most systems do not provide 115200 baud rate.

After setting more than 115.2 thousand computer is not available, use the MCU programming on more than 115.2 thousand in order to use this baud rate and re-issued AT command set up a low baud rate, otherwise it is impossible to return to a lower baud rate.

Well with the AT command set baud rate, the next power-use without re-established, you can power-down to save the baud rate.

C、 To change the Bluetooth name (in February 2008 after 24 new features):

Send: AT + NAMEname

Returns: Okname

Parameter name: want to set the current name, Bluetooth is the name of the search. 20 characters or fewer.

For example:

sending AT + NAMEbill_gates

Back OKname

Then the Bluetooth name to bill_gates

Parameters can be powered down to save, just modify one. PDA-side services can be refreshing to see the Bluetooth name changed.

D、 Modify the Bluetooth pairing password:

Send: AT + PINxxxx

Returns: OK setpin

Parameter xxxx: password pair to be set, 4 bytes, this command can be used from a machine or the host. Slave adapter or cell phone is asked to enter matching password pop-up window, then manually enter this parameter can connect from the machine. The host is using the main Bluetooth module with digital camera, digital camera from the machine, find the camera matching password, and then entered the Bluetooth module is located, then the master Bluetooth module can automatically connect the camera.

For example:

Send: AT + PIN8888

Returns: Oksetpin

Bluetooth pairing password then changed to 8888, the module pair at the factory default password is 1234.

Parameters can be powered down to save, just modify one.